

In Search of Metaphors for Tangible User Interfaces

Dag Svanaes

Computer Science Department
Norwegian University of Science and Technology
Trondheim, N-7034 Norway
+47 73591842
dags@idi.ntnu.no

William Verplank

Interval Research
1801 Page Mill Road
Palo Alto, USA
+1 (650) 842-6072
verplank@interval.com

ABSTRACT

In this paper, we seek to identify interesting sources of metaphor for tangible user interfaces (TUIs). We begin by doing a systematic exploration of the design space that results from constructing simple TUI devices. From this we argue that a new set of metaphors are needed for this domain. From usability tests of simple tangible devices, we suggest that magic and paranormal phenomena could be a fruitful place to look for new metaphors for TUIs.

Keywords

Tangible User Interfaces, Magic, Metaphor, Interaction Design, Ontology, Research Methodology

INTRODUCTION

"Any sufficiently advanced technology is indistinguishable from magic". Arthur C. Clarke's third law applies well to early 21st century technology. For a person teletransported here from the 19th century, our world of 747s, televisions, cellular telephones, and fax machines would seem utterly magical. Flying in the air; seeing at a distance; talking through empty space.

To our technologically blasé generation there is little magic left in television and telephony. We easily forget that we live in a world so different from that of the 19th century that a time-traveler would probably have experienced it as a different universe. Not only has technology changed the speed of communication; our world would be experienced as a universe with a different topology and ruled by different natural laws.

In the Scandinavian countries almost half the adult population now have cellular telephones. This slowly changes the notion of "here" and "there". When you can reach whoever you like from wherever you are, the experience of physical space changes.

Not only does the world get smaller in a quantitative sense, but the topology gets different. The users inhabit a

qualitatively different universe.

In contrast to a technology like the cellular telephone, which changes the topology of the experienced world, a PC with Internet access creates the experience of a virtual cyberspace "inside" the computer. The screen represents the border between "the real" and "the virtual".

Ten years ago, Weiser [16] coined the term "Ubiquitous Computing" to signify work environments that are populated with networked computer systems of all sizes. His vision was to push the computers into the background in such away that they became "invisible" in use.

Since then, much research has been done on moving the user interface out of the screen and into the physical environment of the user, or as Ishii and Ullmer put it: "to change the world itself into an interface" [4, p.238]. We share with Ishii and Ullmer the view that the time is long overdue to go beyond the GUI interface.

They use the term "Tangible User Interfaces" (TUIs) to signify systems that allow for the user to interact with the computer through physical objects (other than mouse and keyboard).

The term "augmented reality" was originally meant to cover a wide variety of approaches to "real-world interfaces", but has become synonymous with head-mounted-display techniques for overlaying the virtual on the real. The latter class of systems is outside the scope of this paper.



Figure 1. The Marble Answering Machine.

One of the most interesting examples to date of a Tangible User Interface (TUI) is Durrel Bishop's Marble Telephone

Answering Machine [2] (Figure 1). In his design, each incoming voice message is represented by a physical marble that pops out of the machine. To listen to a message (marble), you place it on a speaker. To delete the message, you recycle the marble into the machine.

The idea of letting physical objects work as tokens for media content has been explored further by Ullmer in the MediaBlock project [15].

Earlier work at Interval recently reported at CHI'99 [1,12] explored the potential of TUIs for more complex tasks.

Similar ideas have been exploited in a new class of toys from Interval spin-off Zowie Entertainment introducing technology that "connects the toys to the PC and allows children to control onscreen activities through the movement of 3D physical characters and objects" [11].

Most work on TUIs has focused on the use of physical objects as input devices. The "bricks" of Fitzmaurice, Ishii, and Buxton illustrate this [3]. Here physical bricks were placed on a horizontally mounted screen, and used for manipulating virtual objects.

When the physical objects also allow for output, it becomes possible to create the illusion that the computing is happening "in the world". Moving the interaction out of the screen makes it necessary to look for new interface metaphors.

It is only when a tangible interface stops being an interface that it becomes sufficiently advanced to be experienced as "magical" in Clarke's sense of the word. Designing tangible interfaces consequently becomes not only a matter of shaping physical objects and interactive behavior, but of creating new "worlds" for the user to live in.

METAPHORS IN TANGIBLE INTERFACES

To illustrate the role of metaphor in TUIs, we include an example¹. Inspired by the MediaBlocks project [15], we are currently implementing similar systems based on the Dallas Semiconductor iButton technology.



Figure 2. iButton (left) with reader (right).²

As shown in Figure 2, iButtons are shaped as circular battery cells used in many cameras and clocks. They each

¹ The work on iButtons is conducted as part of the thesis work for Marit Anne Pettersen, Rune A. Hollås, and Lena Bjørkli at NTNU.

² Images from <http://www.ibutton.com/>.

have a unique digital ID, and can be inserted into iButton readers connected to a PC.

In one setup, we let iButtons represent Web-accessible mp3 music files. This feature is implemented as a plug-in to the popular mp3-player WinAmp. Each PC has a reader. When an iButton is inserted, WinAmp automatically plays the music associated with that iButton. From WinAmp the user can change music file. The next time the iButton is inserted into a reader on a PC with Internet connection, that music will be played.

In the implementation we have been using passive iButtons with no internal memory. The binding of music-file URLs to iButton IDs is done in a central registry. Even though no information is stored in the iButtons (not even a reference), the system behaves as if the iButtons contained the music.

We see at least three alternative mental models of the system:

1. The iButton contains the music, as if it was a memory card.
2. The iButton contains a reference to the music, as if it could store URLs.
3. The iButton represents the music. (Closest to what actually happens).

As designers the system, we are confronted with this potential ambiguity. Each mental model can be evolved into an interface metaphor. Given that ambiguity is not intended, knowledge of potential sources of ambiguity make us aware of the need to make design decisions concerning interface metaphor.

The choice of metaphor must be supported by both the shape and materials of the physical objects, and by the interaction techniques. What shapes indicate containment, what indicate reference, and what indicate representation? Early tests with 5 users indicate that the shape and material of the iButtons make users see them as containers.

How do we indicate representation? One possibility is to use barcodes instead, as we assume few users will believe that a piece of paper can hold music content. Another choice is to place the iButtons on different LEGO characters. This might make the characters appear as tokens instead of containers. Yet another alternative is to use tokens that look like keys. A key-like shape might indicate that they are "keys" to the information. Later in the project we will test these theories through systematic usability tests.

The iButton-WinAmp example illustrates the importance of identifying the possible ways for a user to understand TUI systems. The above systems gave three possible interface metaphors. Is it possible to identify metaphors that will work for a large class of TUI systems? What stories do users spontaneously tell about these kind of systems, and where can we look for inspiration to novel metaphors for this medium? To answer these questions we have found it

fruitful to do a systematic investigation of the media-specific properties of TUIs.

TANGIBLE INTERFACES AS A NEW MEDIUM

Seen as a new medium, tangible user interfaces are still in their infancy both technologically and concerning our understanding of their media-specific properties.

How does one explore the potentials of a new technology? One way is to start building example applications. A lot can be learned from building demonstration systems, but there is a danger of focusing too much on what is *technologically* possible, and losing sight of the new *design space* opened up by the technology.

Fitzmaurice et al. [3] list twelve dimensions concerning TUIs. These include “spatially aware”, “Input & Output”, and “Communication”. All twelve axes are about choices of technology from a technical point of view. They say little about how users structure their interactive experiences with TUIs.

Bauhaus as Inspiration

Another way of exploring the design space of a new medium is to try to identify its dimensions and basic elements from the user’s point of view. This approach was first followed in the visual arts by modernist painters like Kandinsky, Klee, and Mondrian. To use Kandinsky as an example, he identified *form* and *color* as the two dimensions of the plane, and then went on to identify the elementary form and color elements from which a “composition” could be made.

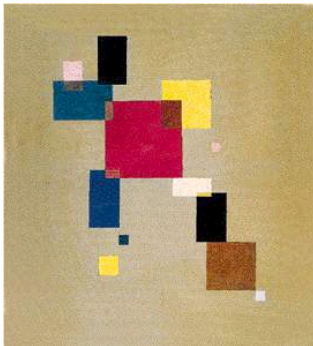

Figure 3. Kandinsky’s “13 Rectangles”.

Kandinsky saw abstract paintings like his “13 Rectangles” (Figure 3) largely as explorations of the design space of form and color.

Itten, Kandinsky’s colleague at the Bauhaus School of Design and Architecture, based his art classes on a similar search for the properties of materials [5]. By systematically exploring different materials, the students learned to see the design spaces that emerged, and new products were born.

International Style and Functionalism resulted from this “modern” approach to arts and craft at the Bauhaus in the 20s. Itten’s pedagogy still influences art and design schools worldwide.

One drawback with the modernists’ approach to media exploration is the total lack of an empirical grounding concerning choice of dimensions and elements.

Design Strategy

Inspired by the Bauhaus approach, we see the exploration of the design space of a new technology as involving three steps:

1. Finding the dimensions and elements of the technology (medium). This can be done as a formal exercise, but should be grounded in empirical studies of how users structure their experiences with the technology.
2. Building simple demonstrators illustrating the dimensions and elements. Kandinsky did this on the canvas by making abstract paintings.
3. Finding metaphors that fit the new class of applications. This search can be formal, inspired by usability tests, or inspired by other media and cultural phenomena.

We hope this search for metaphors guided by a focus on elements will lead to powerful new ontologies for interaction.

Interactive Bits

In [13] Svanaes describes experiments aimed at identifying the dimensions and elements of Graphical User Interfaces (GUIs). A set of simple abstract examples were developed as a way of exploring the design space systematically. An example is shown in Figure 4. On the screen is a white square that goes black when you press on it, and returns to white when you release the mouse button.

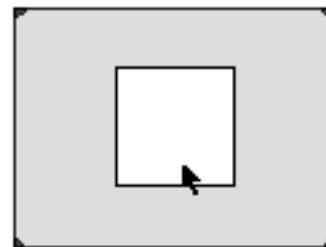

Figure 4. Abstract Interactive Graphics

The State Transition Diagram (STD) of its corresponding Finite State Automaton (FSA) is shown in Figure 5.

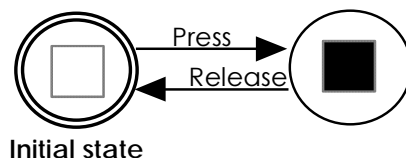

Figure 5. STD for artifact in Figure 3.

From how users described their interaction with this and more complex examples, it was possible to identify a set of implicit metaphors in the users’ understanding of interactivity on the screen. Three kinds of “spaces” were

found in the material: Cartesian space, states space, and linear time.

Lakoff & Johnson's theory of metaphor [7] was used as an inspiration for doing an analysis of the implicit metaphors used by the subjects in describing the interactive behavior.

The FSAs worked as Rorschach tests that brought to the surface the users' implicit metaphors of interactive behavior.

A three-square example will illustrate this further.

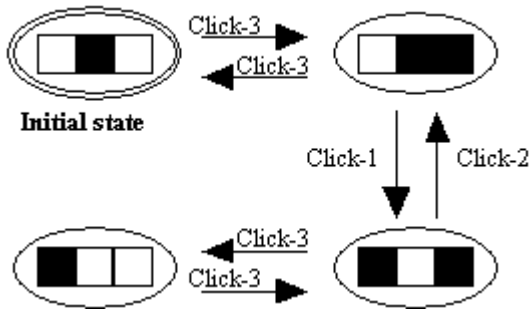
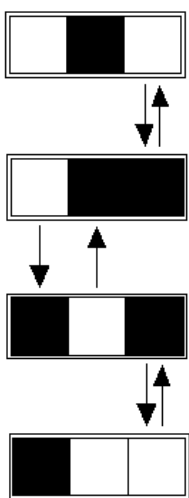

Figure 6. The state transition diagram for an FSA..

Figure 6 shows the state transition diagram of a three-square FSA. The squares are numbered from the left. The FSA starts out in the color combination white-black-white. It has four states.

The color of the rightmost square can be changed by clicking on it. This square has toggle behavior. When the rightmost square is black, it is possible to swap color between the leftmost and the middle square by clicking on the one being white.

The FSA as it appeared on the screen:



The subject's mental model of the FSA:

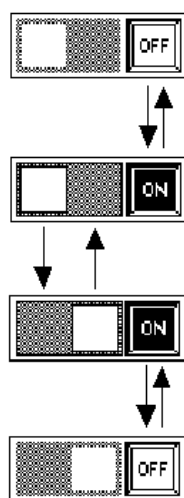

Figure 7. Example of metaphors projected onto a FSA.

One subject (female) described this behavior as:

« ...OK, you have to begin with the one to the right to be able to do anything ... then you can move that one [square 1] ... and turn the one to the right on and off...»

We see here that she saw the FSA as consisting of a switch in position 3 which can be turned on and off, and a white square that can be moved between positions 1 and 2 whenever the switch is "on".

Her mental model of the FSA is illustrated graphically in Figure 7. The visual appearance shown is intended to illustrate graphics that might amplify this test subject's choice of metaphor over other interpretations.

Mobile Interactive Bits

Following this approach to media exploration, we aimed at performing a similar reduction-to-the-absurdly-simple in the TUI domain.



Figure 8. Bringing the squares out of the screen.

As illustrated in Figure 8, this can be seen as bringing the squares of the screen-based experiment out into the world. How does this change the perceived structure of this world, and what is the new design space?

Single-bit interactive devices

The simplest possible interactive device has one bit of input and one bit of output.

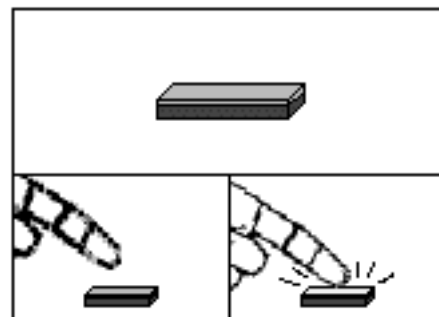

Figure 9. A tile with push-button behavior.

As illustrated in Figure 4, a single square on the screen with the mouse button as the sole input device is an example of

such a device in the GUI domain. A TUI artifact corresponding to this device could consist of a switch and a light bulb. Figure 9 shows an example of such an artifact. It is a single button with built-in light mounted on a small tile. Given a battery and some electronics, it could be configured to have different behaviors such as push-button, toggle, and double-click toggle. The design space of this artifact is the same as for a single black and white square on the screen.

With a set of such tiles in front of you, you can start configuring them into patterns. If you give all tiles toggle behavior, you could for example build a simple font editor by placing them in as a matrix as in Figure 10.

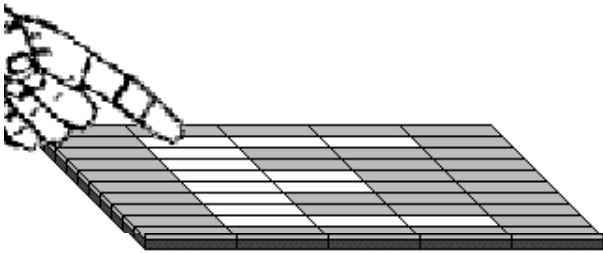

Figure 10. A 10x5 matrix of tiles.

Another example is to use 64 tiles as pieces in the game Othello (Reversi). Othello is played on an 8x8 grid with pieces that are white on one side and black on the other. When taking over a piece from the opponent, one flips the piece to change color. Using interactive tiles with toggle behavior as pieces, flipping could be done by tapping the tiles.

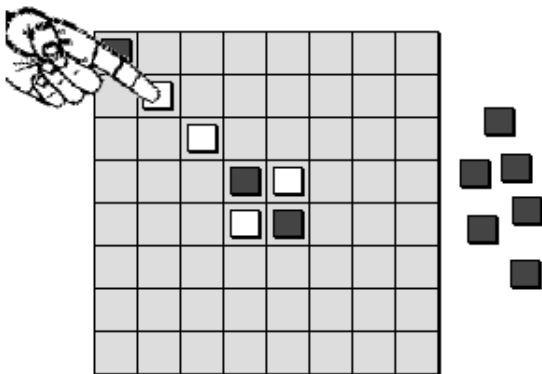

Figure 11. Mixing the real and the virtual.

This is illustrated in Figure 11. We see in the Othello example a mix of virtual and real that is typical of TUI design.

Communicating Mobile Interactive Bits

The design space for isolated single-switch tiles is limited. By adding a mechanism for inter-tile communication one opens up a new dimension in the design space. Let us start by adding hardware for infrared communication that enables the tiles to communicate with their neighbors (Figure 12). This enables us to build behavior to explore

concepts such as causality, identity, and foreground/background.

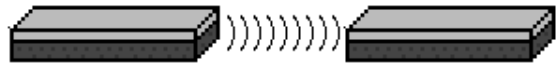

Figure 12. Adding infrared communication.

Causality

A simple example could be to program the tiles to take input only from their neighbor's button. No matter whether we gave the tiles push-button, toggle or other kinds of behavior, this would create the impression that one tile worked as "remote control" for the other. Figure 13 shows how touching one tile leads to change in its neighbor.

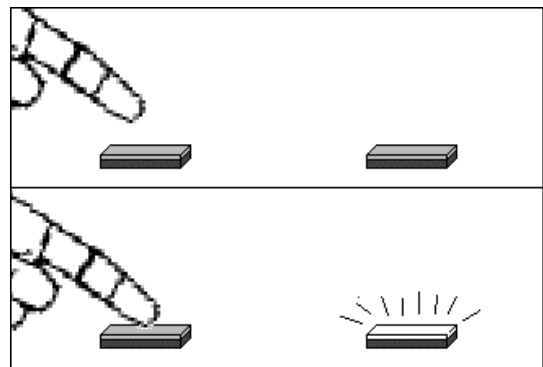

Figure 13. "Remote control"

Identity

If we change the behavior such that the tile's input now goes both to its neighbor and to itself, we create a different impression.

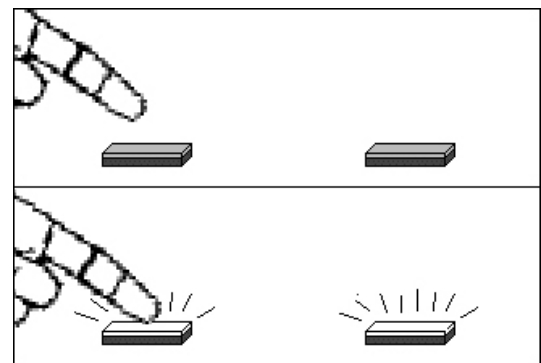

Figure 14. Synchronized behavior.

If both tiles have push-button behavior, the two tiles would now appear as one. Figure 14 shows this. No matter which button you press, both lights go on. Taken away from each other (outside IR-range) the tiles regain their separate identities and are no longer experienced as a unity.

Foreground/Background

If we change the push-button behavior into toggle behavior, we get a similar effect. If we now turn one tile on and the

other one off before bringing them together, we get a light that seems to move between the two tiles when you tap on them. This illusion enables us to do things like moving the light from one tile to another and then bring the light with us to the next room where it is “transferred” to a third tile.

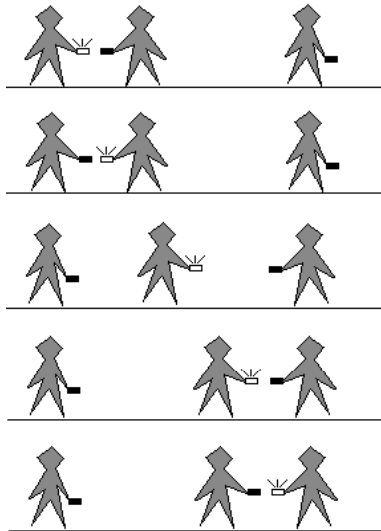

Figure 15. The light as token.

As shown in Figure 15, the light becomes a token that can be moved between tiles.

One possible application of such a setup could be to let each person in an office environment have such a tile, and then let the light represent the responsibility for some activity like putting on coffee.

With a slight modification of the “token” behavior, one could simulate fire. The tiles become torches that can be lit by placing a lit torch close to another torch.

Interconnected Mobile Interactive Bits

Direct tile-to-tile communication has certain limitations. In the *identity* example, pairs of tiles behave as one only as long as the tiles are pointing towards each other and are within IR-range. When you take one of the tiles into the next room, both tiles regain their separate identities. If we want the tiles to be able to form pairs that stay synchronized within a larger area, we have to make use of a different communication technology. Instead of improving the range of the point-to-point communication, we could wire up the environment in such a way that the tiles could communicate through a computer network. This is similar to the transition from point-to-point radio communication to GSM and other techniques used in today’s mobile telephone systems (Figure 16).

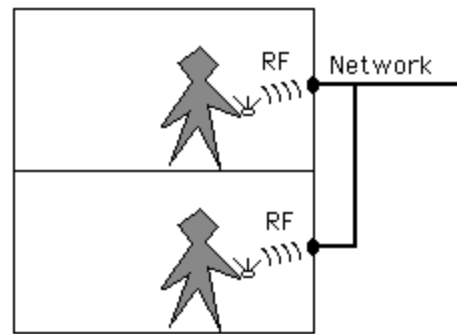

Figure 16. Interconnected devices.

The One-Bit Pager

With tiles that are interconnected in this way it is possible to implement a new class of behaviors. One of the simplest examples is the one-bit pager. It has toggle behavior, and is synchronized with one and only one other tile. When pairs of tiles are synchronized in this way within the area of potential use, they become a possible communication medium between pairs of users.

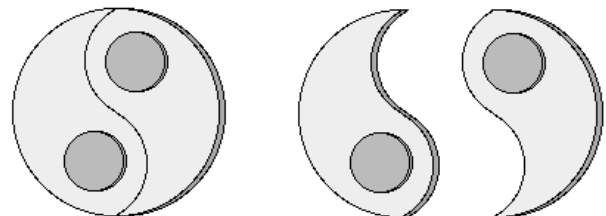

Figure 17. YinYangs that come as pairs.

Inspired by the Yin-Yang symbol, the pairs could be shaped like halves that fit together. A possible product name could be a *YinYang*. Figure 17 shows to the left how the *YinYangs* come as wholes. Taken apart, they become two identical halves.

Possible uses of *YinYangs* include:

- 1.Lunch coordination: You share a *YinYang* with a frequent lunch partner. Turning the *YinYang* on means “Are you ready for lunch?”
- 2.Dinner coordination: A parent could share one pair with each child and place the halves on the fridge. To inform the kids that dinner is ready, one would tap on the *YinYangs* on the fridge. The kids’ halves would then light up.

Families of Devices

If in the fire example we wanted torches that could be lit only from other torches, we would need some way of lighting the first torch. One solution to this problem would be to define *lighter* as another kind of tile behavior. *Lighters* could then be used to light *torches*. By giving tiles different behavior in this way, one can create “worlds” of objects that work together.

To signify that TUI objects have different behavior, it is often useful to let them differ also in shape and color.

EMPIRICAL GROUNDING

To be able to test out empirically how mobile interactive artifacts are perceived in use, we have done some initial experiments with screen-based simulations. The simulations explore behavior similar to those explored here.

We have not yet performed a full usability test, nor finished the construction of the physical devices. We have only done some informal tests with a limited number of users, but we chose to present this as it hopefully gives some indication of interesting phenomena to study further.

First we found that the Yin-Yang symbol has a rich cultural meanings; we would probably not use it in a product. From descriptions of the behavior, we have so far identified the following fundamental metaphors:

- Cartesian space
- State space
- Linear time
- Relational metaphors (human relations)
- Paranormal phenomena

We see that the two fundamental metaphors that are new to this domain relate to human relations and non-standard worldviews.

HUMAN RELATIONS

The fundamental metaphor at work when users describe TUI behavior in relational terms is to see emotional closeness as physical closeness. In a way, the metaphor works both ways in that physical closeness also creates emotional closeness. We are dealing with a "relational" universe with a topology different from the physical universe.

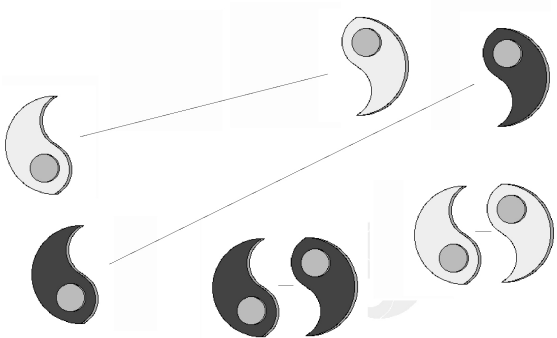

Figure 18. YinYangs that can be reconfigured.

One of the screen-based simulations involved a version of the *YinYang* where a collection of halves initially started out as isolated toggle switches. To connect a half to another half, one had to place the two halves close. You could further change connection at any time by placing a half close to another half. Figure 18 shows a screenshot from the

simulation with lines added to show how the *YinYangs* were connected. The lines did not appear in the simulation.

This example was frequently described in relational metaphors like "switching partner", "monogamy", "being single", "finding a partner", "breaking a relationship", and "infidelity". Some interesting design details emerge from this. Should pagers be allowed to "form pairs" with other pagers, or should they come as "twins"/"eternal lovers"?

MAGIC AS AN INTERFACE METAPHOR

During our experimentation, we repeatedly found ourselves and others comparing our prototypes with paranormal phenomena: "This is like telepathy", "This is like Voodoo". This observation led us to explore our tacit expectations of the paranormal. Are there any common themes in our expectations of the magical? What is the structure of this world?

If well understood, this "universe" could be both a source of inspiration and a provider of metaphor for TUIs. The hypothesis is that users would find systems with "magical" behavior easy to understand because it behaved according to their tacit expectations of magic.

This is not to say that the resulting products should make explicit a "magical" metaphor. The "paranormal" is explored here mainly for the purpose of providing interesting coherent structuring principles for a new technology. At this stage we want to try out a variety of metaphors.

Our use of "magic" here is different from Tognazzini's use in [14]. Here Tognazzini argues for the application of techniques from stage magic to interface design. We use "magic" to refer to belief systems different from that of Western rationality, that allow for phenomena that are "impossible" in the latter system.

The following is a tentative discussion of some interesting aspect of the magical that could serve as inspiration for Tangible Interfaces.

Telepathy and Quantum Mechanics

Telepathy is often thought of as direct mind-to-mind communication across space. As such, its closest technological realizations are the cellular and the pager.

Most anecdotes of telepathy tell the same story: Telepathy tends to happen spontaneously mostly between people who are emotionally close.

- The sailor drowning at sea who shows up in his wife's dream saying goodbye.
- Close friends or family members who have not spoken for weeks, where both pick up the telephone at exactly the same time to call the other.
- Twin pairs who know the emotional state of the other across thousands of miles.

The importance of emotional closeness to the success of telepathy is according to Radin [9] also found in

experimental studies of telepathy. The widespread use of spatial metaphors to describe the strength of emotional connections between people indicates that users will not have any problem understanding this concept.

Applied metaphorically to the physical world, telepathy has a close resemblance to a phenomenon in quantum mechanics referred to as Bell's theorem or "nonlocality". The idea is that when two particles have constituted a system, they continue being a system across space.

Quantum mechanics is very hard to interpret in everyday terms. The theory seems to indicate that this effect can not be utilized to transmit information across space. This has to do with the nature of doing measurements.

The *YinYang* can be seen as an example of "nonlocality". When two pagers have formed "a system", they continue being "a system" across space.

Relics and Magic

A belief found in many cultures is that physical objects can carry magical power:

- A piece of the Holy Cross can carry with it magical power from Christ.
- Hair from an enemy can be used by a Voodoo priest to cast a powerful spell on him.
- A scarab from the tomb of a Pharaoh will forever bring disaster to its owner.

The "relics" metaphor is ambiguous concerning the reference back to the source of the "power". In the Voodoo example, the reference is definitely there, while the piece of the Holy Cross becomes a powerful artifact on its own.

The fundamental metaphor at work here is the object as container. This metaphor has been utilized in applications like Durrel Bishop's "marble" answering machine [2] and Ulmer's MediaBlocks [15].

The magical-power metaphor also allows for objects to pick up properties like behavior and color from other objects. One possible application could be a GPS device or similar that recorded the objects you touched. It would then "carry with it" the properties of these objects.

Even though it is convenient to refer to this metaphor as a container metaphor, some users will probably experience the container as the object. In Bishop's answering machine, the marbles might as well "be the messages" as "containing the messages".

The body as container

Applied to TUI design, the idea of using the body as container for information could for example be utilized to let you add URLs to your personal list of URL favorites by touching the computer screen with your index finger. Technologically this could be implemented by finger print recognition or other means of identifying the user.

Another example is to allow different parts of the body to be carriers of information. Imagine a touch screen technology that is able to identify which of the user's 10 fingers is used for pointing. This would enable a multi-finger cut and paste which might be convenient in certain situation. In a slide-sorter application, you could for example have a virtual slide on each finger.

The Holistic Universe and Magic Through Resemblance

Many magical rituals involve creating an image that looks like the thing it is intended to represent. We will call this "magic through resemblance".

- The Voodoo priest makes a doll that resembles the victim.
- Christian churches are built with a cross-shaped base.
- By putting physical objects in a certain order, some kind of contact is established with a similar structure present or past.

A modern version of "magic through resemblance" can be found in Rupert Sheldrake's concept of the morphic field[10]. His idea is that the universe has a collective memory that makes it easier to do something when it has already been done somewhere else. His two most cited examples are:

1. When researchers in one lab have taught their rats to run a new maze for the first time, it takes less time for rats in all other labs on the planet to learn the same trick.
2. When a chemical substance has been created in one lab, it is easier to create it in other labs. This has to do with the time it takes to crystallize the new compounds.

Sheldrake also refers to this effect as formative causation, even though it differs somewhat from formative causation in the classical Aristotelian sense.

Similar ideas can be found in David Bohm's theory the Holographic Universe and Carl G. Jung's concept of the collective subconscious.

How to specify TUI behavior

The idea of a collective memory can be utilized as a way of mapping configuration to behavior. Let the interactive tiles work as an example. Given that we have global communication, i.e. all tiles communicate through a network. How do we allow the users to change the behavior of the tiles?

One way is to see behavior as something that is downloaded to the tiles as you do when you program LEGO's MindStorms robots. Another way is to let the tiles pick up behavior when placed in a certain "zone". Tiles could also get behavior from other tiles as Kramer's programmable tiles [6]. Yet another way would be to allow for the configuration of the tiles to specify the behavior through some kind of visual programming formalism.

Inspired by the idea of collective memory, an alternative way of specifying the behavior of a set of tiles would be to

place them in a configuration that corresponds to a certain learned behavior. When you place three tiles on top of each other they could start working as an elevator. It would not be because of an emergent property of their collective behavior, but because someone else with the skill to do so has once instructed the tiles *as a species* to become an elevator when placed in that specific configuration. The configuration works as a signature for the behavior, much in the same way as the letter combination “emacs” is the signature of a specific UNIX application.

To implement this feature, one would need to have a central registry of behaviors with corresponding configurations. When a known configuration was recognized by the network, a new set of behaviors would be automatically downloaded to the TUI devices.

RESEARCH QUESTIONS

For Tangible User Interfaces to become more than an interesting technological possibility, designers, and software developers must be given the opportunity to design and assemble products from a set of easily accessible components. The TUI technology is currently in a state similar to that of GUIs before the existence of windowing systems and widget sets. To move forward it is consequently necessary to develop useful middleware and TUI standards to speed up the development cycle.

A number of questions need to be answered before this can be done:

- What are the most effective metaphors and conceptual models which help map applications to common elements and how they are programmed.
- What will constitute a useful set of interaction elements for the TUI domain? What should be its Windows, Icons, Mouse and Pull-Down menus (WIMP)? To answer this question a lot of experimentation needs to be done. One way of approaching the problem could be to start out with basic hand operations like placing, picking up, moving, pointing, collecting, assembling, de-assembling, stretching, pushing, pulling, touching, rubbing, and shaking. From this there might emerge a tacit interaction language, and a set of objects.
- How should the TUIs be programmed? The answer to this question is pointed to by saying that TUI elements could be subclassed in a similar manner as is currently done with GUI elements. (E.g. Java’s AWT, and Smalltalk’s MVC classes). Technologically there is a need to build a runtime system between the programming level and the TUI hardware. There will also be a need for something similar to an Inspector/Browser to enable developers to debug and test out the software. There is a potential here for integration with component technologies like COM or CORBA/JavaBeans. A small set of test applications should be developed with the TUI kit as a showcase.

ACKNOWLEDGMENTS

We would like to thank Hiroshi Ishii, Gillian Crampton-Smith, and Bill Gaver for helpful feedback.

REFERENCES

1. Cohen, J. et.al. "Logjam: a Tangible Multi-Person Interface for Video Logging" *Proceedings of the ACM SIGCHI Conference on Human Factors in Computing Systems*, Pittsburgh, 1999.
2. Crampton Smith, G. "The Hand That Rocks the Cradle", *I.D.*, May/June 1995, pp. 60-65.
3. Fitzmaurice, G. W., Ishii, H., and Buxton, W. "Bricks: Laying the foundations for graspable user interfaces", In *Proceedings of CHI '95*, pp 442-449. ACM, 1995.
4. Ishii, H., and Ullmer, B. "Tangible Bits: Towards Seamless Interfaces between People, Bits, and Atoms", *Proc. of CHI'97*, pp. 234-241, ACM 1997.
5. Itten, J. *Design and form : the basic course at the Bauhaus*, London: Thames and Hudson, 1975
6. Kramer, K. H. *Moveable Objects, Mobile Code*, MIT MediaLab, 1998.
7. Lakoff, G. and Johnson, M. *Metaphors we live by*. Chicago: University of Chicago Press, 1980.
8. Laurel, B. *Computers As Theatre*, Reprint edition, Addison-Wesley Pub Co, 1993.
9. Radin, D. I. *The Conscious Universe : The Scientific Truth of Psychic Phenomena*, Harpercollins 1997.
10. Sheldrake, R. *New Science of Life : The Hypothesis of Formative Causation*, Hardcover, Saunders of Toronto Ltd, 1981.
11. Shwe, H. and Francetic, A., "Smarter Play for Smart Toys: The Benefits of Technology-Enhanced Play" *A Zowie Entertainment White Paper*, 1999. <<http://www.zowie.com/who/whitepaper.html>>
12. Singer, A., et. al. "Tangible Progress: Less Is More In Somewire Audio Spaces," *Proceedings of the ACM SIGCHI Conference on Human Factors in Computing Systems*, Pittsburgh, 1999.
13. Svanaes, D. "Kinaesthetic Thinking: The Tacit Dimension of Interaction Design", *Computers in Human Behavior*, Vol 13, No. 4, pp. 443 - 463, 1997, Elsevier 1997.
14. Tognazzini, B. Principles, Techniques, and Ethics of Stage Magic and Their Application to Human Interface Design. *Proceedings of the ACM INTERCHI'93 Conference on Human Factors in Computing Systems*, pp 355-362, Amsterdam , 1999.
15. Ullmer, B, et. al. "mediaBlocks: Physical Containers, Transports and Controls for Online Media", *Proceedings of the ACM SIGGRAPH*, Orlando, 1998.
16. Weiser, M. (1991). The computer for the 21st century. *Scientific American*, 265(3):94—104, 1991.